

AIRHANDLE

WEIGHTLESS HANDLING



HOFPARTNER AB
TECHNOLOGY AT THE CORE



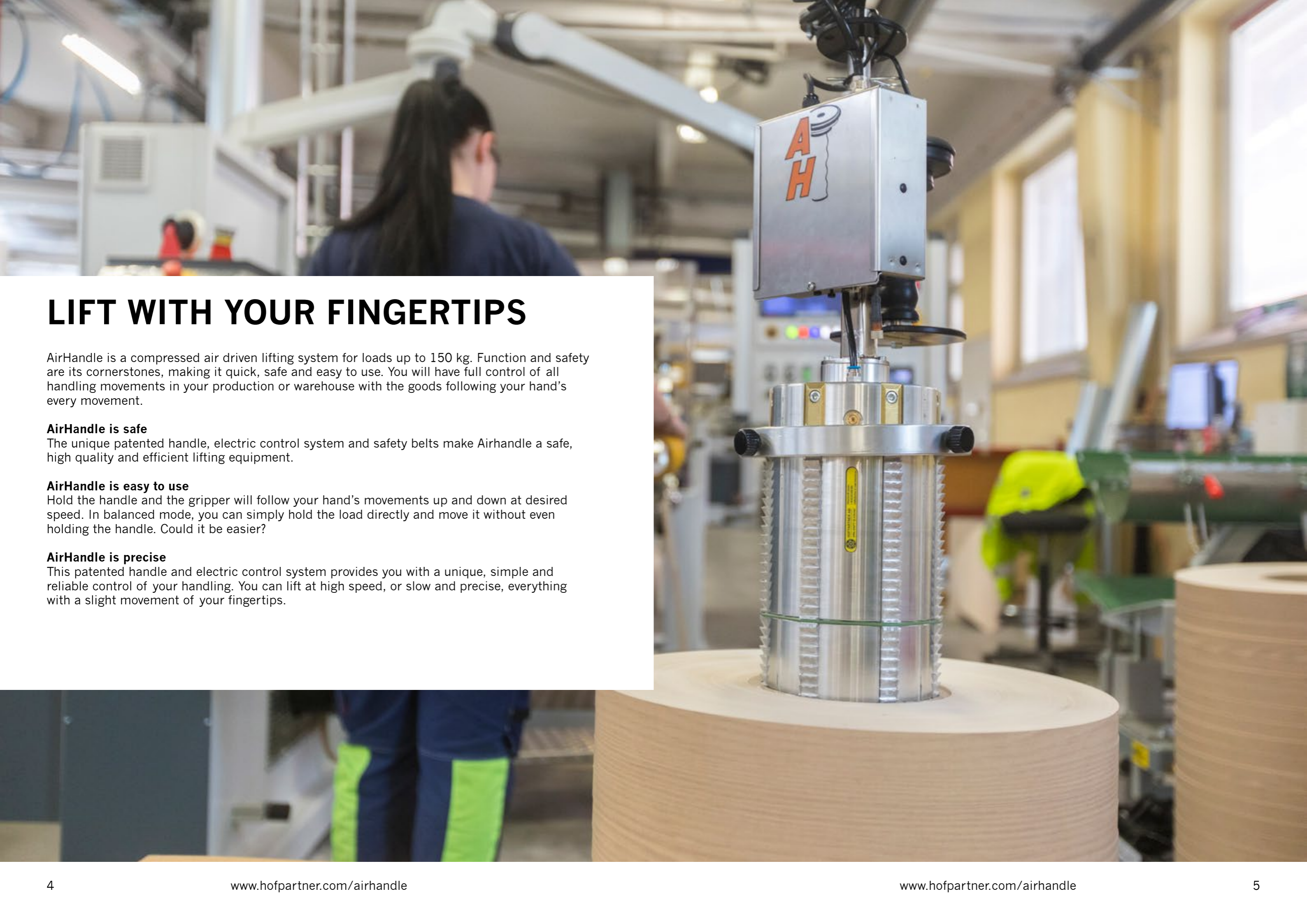

LIFT WITH YOUR FINGERTIPS

AirHandle is a compressed air driven lifting system for loads up to 150 kg. Function and safety are its cornerstones, making it quick, safe and easy to use. You will have full control of all handling movements in your production or warehouse with the goods following your hand's every movement.

AirHandle is safe

The unique patented handle, electric control system and safety belts make Airhandle a safe, high quality and efficient lifting equipment.

AirHandle is easy to use

Hold the handle and the gripper will follow your hand's movements up and down at desired speed. In balanced mode, you can simply hold the load directly and move it without even holding the handle. Could it be easier?

AirHandle is precise

This patented handle and electric control system provides you with a unique, simple and reliable control of your handling. You can lift at high speed, or slow and precise, everything with a slight movement of your fingertips.



AIRHANDLE CRANE

AHC-80

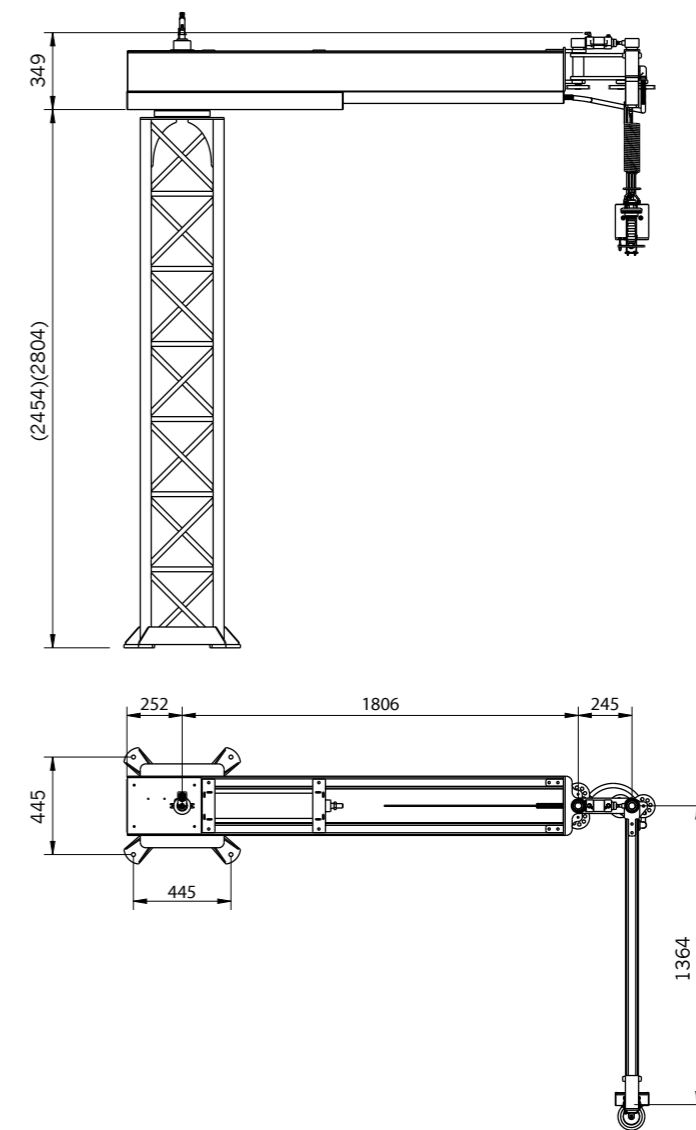

AIRHANDLE AHC-80

Maximum load	80 Kg
Stroke	2000 mm
Arm length	3000 mm
Rotation	360°
Air supply	6 Bar
Electrical supplu	110-230 VAC



AIRHANDLE RAIL

AHR-60/40, FOR OVERHEAD RAILS

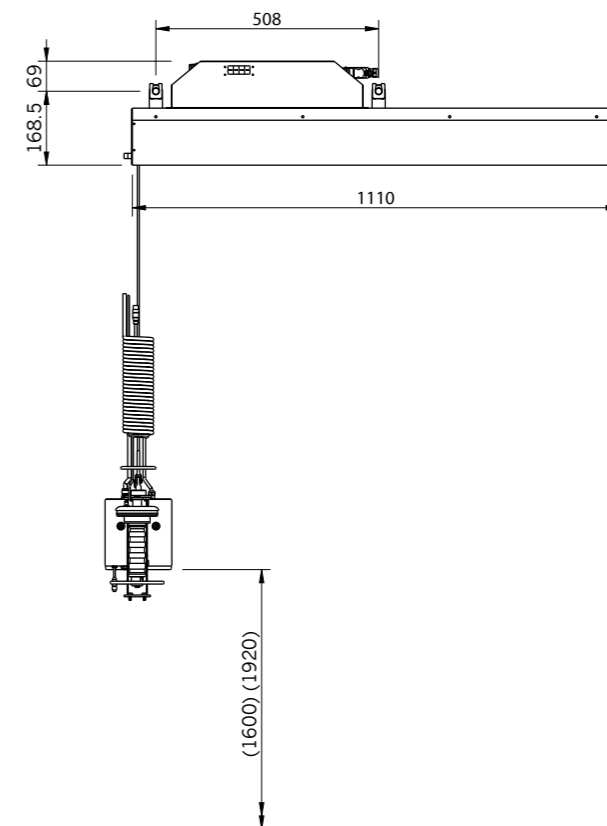

AIRHANDLE AHR-60/40

Maximum load	40/60 Kg
Stroke	1920/1600 mm
Air supply	6 Bar
Electrical supply	110-230 VAC



AIRHANDLE SINGLE CYLINDER

AHS-150 -8/-10/12, FOR OVERHEAD RAILS

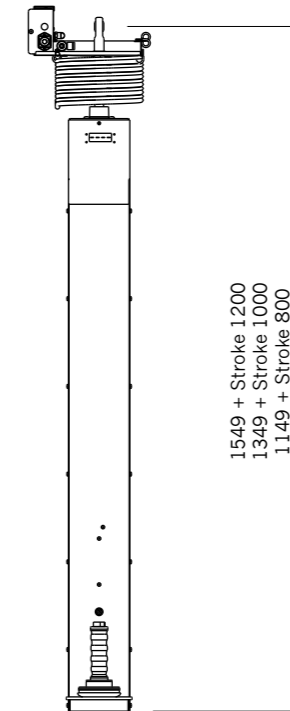

AIRHANDLE AHS-150 -8/-10/12

Maximum load	150 Kg
Stroke	800/1000/1200 mm
Air supply	6 Bar
Electrical supply	110-230 VAC

FEATURES

All lifting functions and grippers are controlled by the electric control system. Several parameters can be adjusted to optimize different grippers and lifting situations. The AirHandle lift has as a standard all safety and functions needed for quick installment and safe and easy handling.

Safety

- AirHandle is set to correspond to gripper payload, which prevents lifting more than the maximum load.
- AirHandle prevents the load from being released in mid-air.
- AirHandle gives a feedback signal from the gripper when the load is safely gripped.

Functions

- Choose if you want the lift to be able to work in a counterbalanced lifting mode, lifting can then be done by moving the load itself without using the handle.
- You can adjust the handle's sensitivity, deadband and amplification of the AirHandle signal.
- Four different configurations possible, which you can change with a simple push of the button.



Airhandle is customizable
Use our standard solutions or our tailored grippers, we have everything from a simple hook to advanced vacuum grippers.

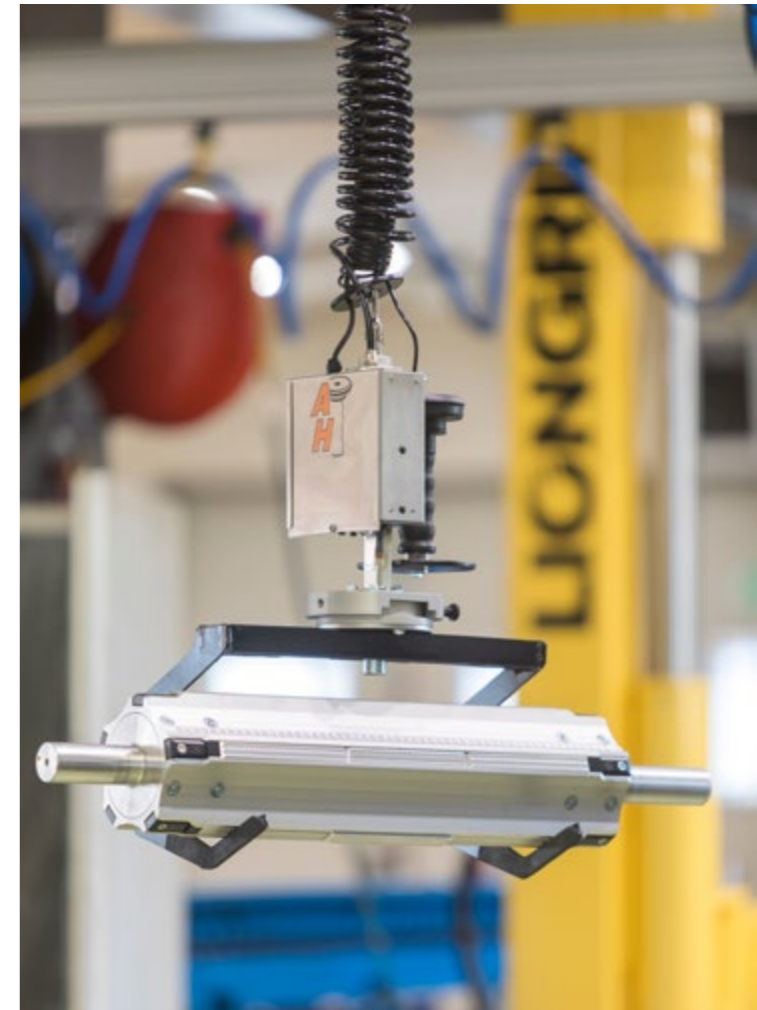

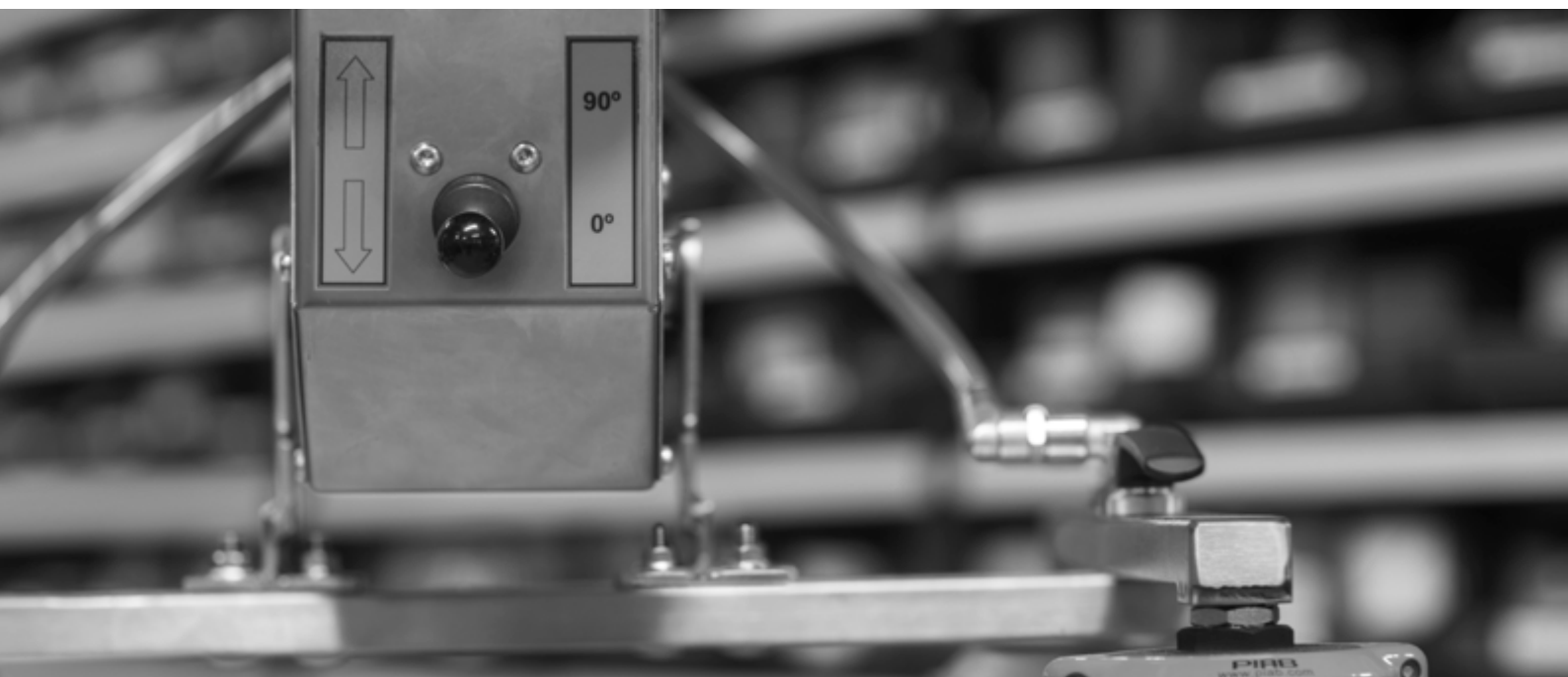

HOFPARTNER AB

TECHNOLOGY AT THE CORE

Hofpartner AB
Mor Annas väg 1
662 32 Åmål Sverige

Tel. +46 (0)532 60 85 80
Mail info@hofpartner.se